



**The Clear Choice**  
Water Filtration Systems

www.aquafilter.com

# H10B series

10" filter housings for cold water



Part Nr.	Size
FHPR12-B1-AQ	1/2"
FHPR34-B1-AQ	3/4"
FHPR1-B1-AQ	1"

Part Nr.	Size
FHPR12-B-AQ	1/2"
FHPR34-B-AQ	3/4"
FHPR1-B-AQ	1"

Part Nr.	Size
FHPRN12	1/2"
FHPRN34	3/4"
FHPRN1	1"

- Set include:**
- 10" filtr housing
  - filter cartridge 5 µm (FCPS5),
  - mounting bracket with screws
  - wrench
  - instruction
  - color box
  - antibacterial and antimicrobial filter cartridge centralizing ring



This Cartridge is Tested and Certified by NSF International against NSF/ANSI Standard 42 for materials requirements only.

COMPONENT



## General Description:

**AQUAFILTER H10B series housings** - 10"-type filter housings offer the versatility to meet all customer filtration needs. **H10B Series** consists of **FHPRx-B-AQ, FHPRx-B1-AQ, FHPRNx Series**.

They are all dedicated for cold water on residential and commercial applications. **H10B series** housings are compatible with a broad range of 2 1/2" x 10" type cartridges widely available on the market.

**FHPRx-B-AQ, FHPRx-B1-AQ series** filter housings consist of a transparent sump and head with brass 1/2", 3/4" and 1" inlet/outlet inserts and two O-rings (one placed around sump thread and the other inside filter head).

A transparent sump allows for the evaluation of cartridge contamination.

**FHPRNx Series** consists of blue sump, ring and head with brass 1/2", 3/4" and 1" inlet/outlet inserts and two O-rings (one placed around sump thread and the other inside filter head).

Heads are equipped with a pressure relief valve (providing ability to release air pressure collected during cartridge replacement procedure).

Utilization of two O-rings ensures maximum leak-proof performance. Optionally, filter housings can be equipped with additional features, such as: mounting bracket, wrench or filter cartridge (for details refer to product brochure). The **H10B Series** housings can be mounted individually or connected in a series.

To **FHPRx-B1-AQ series** housing an antibacterial centering ring is added. **TOTALLY FREE OF CHARGE!**

## Features:

- High quality
- NSF certified for structural integrity and material requirements
- WRAS certificate
- FDA CFR Title 21 Compliance
- Competitive Pricing
- Factory Tested
- Two O-rings for maximum leak proof protection
- Domestic and commercial use
- Equipped with filter bracket, wrench and cartridge\*
- Equipped with antibacterial and antimicrobial filter centralizing ring\*
- Ideal for POE or POU use
- Maintenance Free -Saves \$, Time and Labor
- Easy to connect to cold water inlet
- Easy to install, No Electricity, No Drain Required
- Full flow 1/2", 3/4" or 1" ports
- Made in EU with High Performance Components

\* only in **FHPRx-B1-AQ**

## Applications:

- Domestic installations
- Pre-filtration systems
- Food industry
- Industry laboratories





**The Clear Choice**  
Water Filtration Systems

www.aquafilter.com

# H10B series

10" filter housings for cold water

## Additional accessories



### Specifications:

**Clear Housing (sump):** poly(ethylene terephthalate) (PET)  
**Blue Housing (sump):** polypropylene  
**Cap:** polypropylene  
**Inserts:** brass  
**Pressure relief valve:** brass  
**O-ring:** NBR  
**Number of orings:** 2  
**Thread:** 1/2", 3/4", 1" BSP  
**Operating Pressure:** 6 bar (90 psi)  
**Minimum working temperature:** 2°C (35°F)  
**Maximum working temperature:** 45°C (113.00°F)\*  
**Dimensions without bracket (H x OD) 1/2":** 305 x 120 (mm)  
**Dimensions without bracket (H x OD) 3/4", 1:** 315 x 120 (mm)  
**Dimensions with bracket (H x W x L) 1/2":** 345 x 120 x 140 (mm)  
**Dimensions with bracket (H x W x L) 3/4", 1:** 355 x 120 x 140 (mm)  
**Cartridge dimensions:** 9 7/8" x 2 1/2" (250 mm x 65 mm)

\* Tested and certified by WRAS for 23°C only.

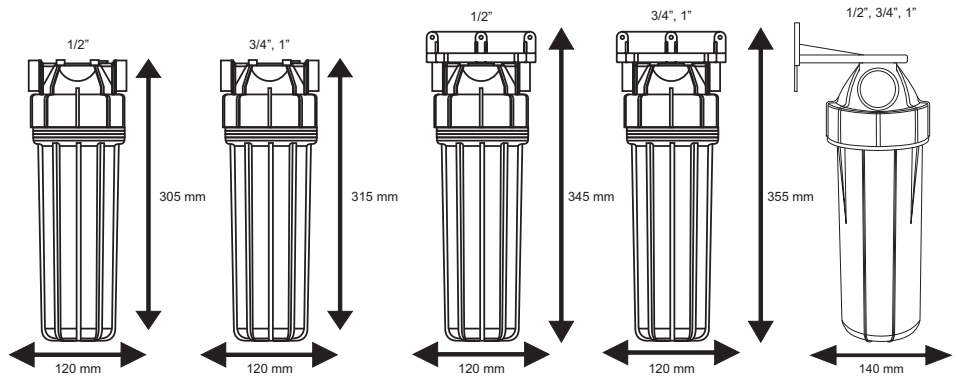
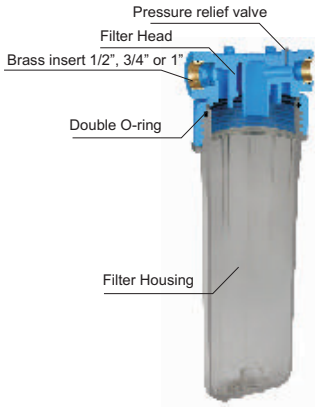
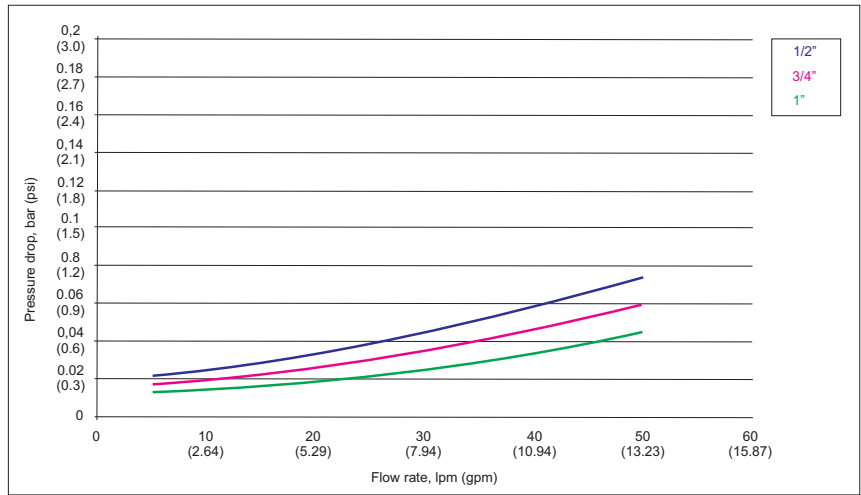

### NOTE

- Do not use with water that is microbiologically unsafe or of unknown quality without adequate disinfection before or after the system.
- Water filtration systems can help reduce the presence of contaminants. In addition, some water filtration systems can help reduce the presence of microorganisms or other contaminants with potential health effects.
- We strongly recommend regularly scheduled maintenance and replacement of the filter cartridge in order for the product to perform properly.
- Replace the filter cartridge at least every 6 or 12 months (depending on water quality and water consumption)

**LIMITED WARRANTY:** Manufacturer warrants that this product is free from defects in materials and workmanship. This warranty, together with any and all warranties implied by law, shall be limited to a period of five (5) years from the date of original purchase.

This limited warranty does not apply to failures that result from abuse, misuse, alteration or failure to properly comply with installation, or cartridge change instructions. We strongly recommend adding to all point of use and point of entry a Pressure Limiting Valve to guard against unwanted extreme water pressure events pressure increases, surges, and water hammer which could occur in the water pipes. Not having one installed could mean that if you ever did have to claim damage caused by a burst water filter system, the claim will be denied.

All Aquafilter images, trademarks, logos, and other intellectual property are the sole and exclusive property of Aquafilter, Inc. and may not be used without our express written permission.



**Aquafilter Manufacturing Facility**

**Aquafilter Inc.**  
Hunt Valley 21030, USA  
us@aquafilter.com

**Aquafilter Germany**  
15234 Frankfurt, Germany  
de@aquafilter.com

**Aquafilter Europe**  
91-222 Lodz, Poland  
pl@aquafilter.com

